



Falcon™ Pumps

Oil and Grease Lubrication Pumps

NEW FALCON!
Graco's
newest pump
outperforms the
competition—
UP TO 33%!

Falcon Oil and Grease Pumps: Dollar for dollar and stroke for stroke, few pumps can match the Falcon's performance in dispensing medium-volume lubricants.

Fast-Ball 1:1: Redesigned to perform optimally at lower air supply pressures

■ The Falcon 3:1 Ratio Oil and 50:1 Ratio Grease Lubrication Pumps

Graco's Falcon pumps deliver the power and dependability you've come to expect from the leader in lubrication equipment. Even if dispensing oil and grease is only part of what you do, to accomplish it efficiently you need quality equipment. Graco's pumps are powerful enough to handle most types of oil and grease, and they perform dependably under rough conditions.

- 3:1 Falcon delivers higher fluid pressure than other 3:1 pumps—**up to 33% more than the competition!**
- Corrosion-resistant 2.9-inch diameter air motor design – for long life
- Double-acting pump ensures smooth flow
- Pump reliability virtually eliminates downtime

3:1 Falcon



50:1 Falcon



Fast-Ball



■ Fast-Ball® 1:1

The Fast-Ball pump is the ideal choice for the transfer and dispensing of light lubricants such as motor oil, hydraulic oil and ATF. The Fast-Ball is available in stubby length for wall mounting or with various tube lengths to fit containers from 5 to 275 gallons (20 to 1100 liters).

- Now designed to operate at lower air supply pressure
- Great for oil dispense consoles and oil bars
- In-line design with few moving parts for less pump wear
- Differential air motor ensures reliable pumping
- Double-acting pump provides smooth fluid flow

Falcon 3:1 and 50:1 Technical Specifications

	3:1	50:1
Maximum fluid working pressure	650 psi (45 bar, 4.5 MPa)	7500 psi (517 bar, 52 MPa)
Maximum air inlet pressure	150 psi (10 bar, 1.0 MPa)	150 psi (10 bar, 1.0 MPa)
Ratio	3:1	50:1
Pump cycles per volume	28 per gal (7.39 per liter)	.52 per lb. (1.15 per kg)
Volume per pump cycle	0.037 gal (0.140 liter)	.0019 lb. (.008 kg)
Maximum recommended pump speed	115 cycles per minute	115 cycles per minute
Recommended pump speed for continuous operation	95 cycles per minute	95 cycles per minute
Maximum delivery	4.3 gpm (16.3 liters/min)	2.2 lb/min (1.0 kg/min)
	at 115 cycles/minute	at 115 cycles/minute
Stroke length	3.25 in. (82.5 mm)	3.25 in. (82.5 mm)
Maximum pump operating temperature	130°F (54°C)	130°F (54°C)
Air inlet size	3/8 npt(f)	3/8 npt(f)
Fluid outlet size	1/2 npt(f)	1/4 npt(f)
Fluid inlet size	1 1/2 npt(f)	N/A
Wetted parts	aluminum; carbon steel; chrome alloy steel; urethane;	carbon steel; zinc plating; ductile iron; polyurethane;
	Buna-N; acetal; ultra-high molecular weight	ultra-high molecular weight polyethylene;
	polyethylene	Buna-N
*Sound pressure level at 70 psi air and 30 cpm	72.99 dB(A)	72.99 dB(A)
Sound power level at 70 psi air and 30 cpm	85.88 dB(A)	85.88 dB(A)
*Sound pressure level at 150 psi air and maximum cycle rate	79.36 dB(A)	79.36 dB(A)
Sound power level at 70 psi air and maximum cycle rate	92.25 dB(A)	92.25 dB(A)
Instruction Manuals		
Falcon 3:1 Pump		309223
Falcon 3:1 Package		308382
Falcon 50:1 Pump		309224
Falcon 50:1 Package		308300

*Sound pressure levels measured per ISO Standard 9614-2.

*Sound power levels measured per ISO Standard 9614-2.

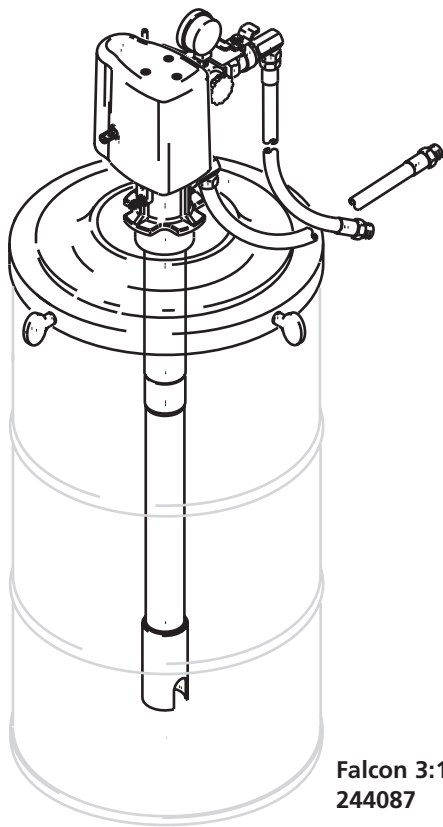

**Falcon 3:1 Package
244087**

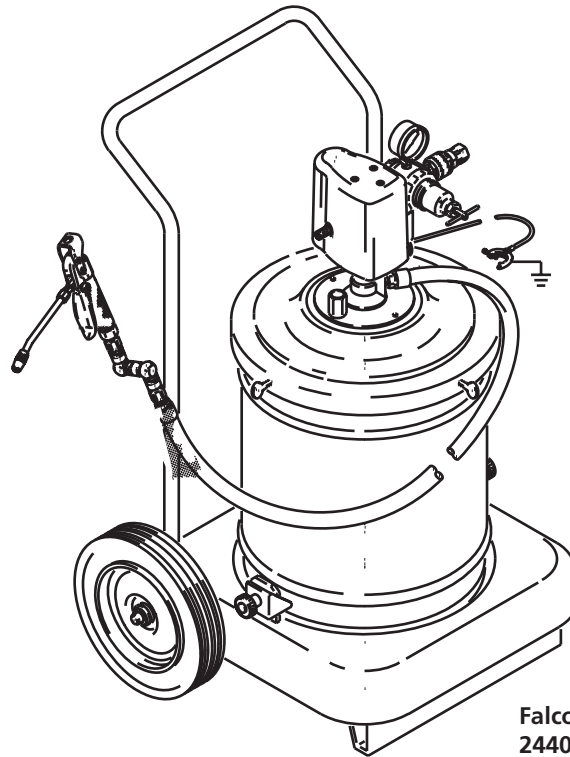

**Falcon 50:1 Package
244098**

Falcon Ordering Information

Falcon 3:1 Pumps

Falcon 3:1 Pump, Universal	244047
Falcon 3:1 Pump, 16 gal (60 L) cover	244048
Falcon 3:1 Pump, 55 gal (205 L) bung	244049
Falcon 3:1 Pump, 55 gal (205 L) cover	244050
Falcon 3:1 Pump, 275 gal (1100 L) bung	244051

Falcon 3:1 Packages

Falcon 3:1 Package, Universal, w/hose/fitting kit, and air reg kit	244085
Falcon 3:1 Package, 16 gal (60L), w/cover, hose/fitting kit, and air reg kit	244086
Falcon 3:1 Package, 55 gal (205 L), w/bung adapter, hose/fitting kit, and air reg kit	244087
Falcon 3:1 Package, 55 gal (205 L), w/cover, hose/fitting kit, and air reg kit	244088
Falcon 3:1 Package, 275 gal (1100 L), w/bung adapter, hose/fitting kit, and air reg kit	244089
Falcon 3:1 Package, bulk oil supply, w/pump, air reg, bung adapter, 350 Series reel, and EM5 meter	244090
Falcon 3:1 Package, bulk oil supply, w/pump, air reg, bung adapter, 250 Series reel, and EM5 meter	244091
Falcon 3:1 Package, bulk oil supply, w/pump, air reg, bung adapter, 250 Series reel, and EM5 meter (Canadian W&M)	244092
Falcon 3:1 Package, bulk oil supply, w/pump, air reg, bung adapter, 350 Series reel, and EM5 meter (Canadian W&M)	244093
Falcon 3:1 Package, 16 gal (60 L), w/cover, disp kit, and portable base	244094

Falcon 50:1 Pumps

Falcon 50:1 Pump, 35 lb (16 kg)	244044
Falcon 50:1 Pump, 120 lb (55 kg)	244045
Falcon 50:1 Pump, 400 lb (180 kg)	244046

Falcon 50:1 Packages

Falcon 50:1 Package, 120 lb (55 kg) w/disp kit, cover, and follower plate	244082
Falcon 50:1 Package, 120 lb (55 kg) w/elevator, and pump support	244083
Falcon 50:1 Package, 400 lb (180 kg), w/disp kit, cover, and follower plate	244084
Falcon 50:1 Package, 35-70 lb (16-32 kg), w/disp kit, cover, and follower plate	244095
Falcon 50:1 Package, 35-70 lb (16-32 kg), w/2-wheel truck, disp kit, pump support, and inductor plate	244096
Falcon 50:1 Package, 35-70 lb (16-32 kg), w/disp kit, cover, and pail	244097
Falcon 50:1 Package, 35-70 lb (16-32 kg), w/2-wheel truck, disp kit, cover, and pail	244098
Falcon 50:1 Package, 35-70 lb (16-32 kg), w/portable base, disp kit, cover, and pail	244099
Falcon 50:1 Package, 120 lb (55 kg), w/portable base, disp kit, cover, and follower plate	244100
Falcon 50:1 Package, 120 lb (55 kg), w/2-wheel truck, disp kit, cover, and follower plate	244101
Falcon 50:1 Package, 120 lb (55 kg), w/Heavy-duty 2-wheel truck, disp kit, cover, and follower plate	244102
Falcon 50:1 Package, 35 lb (16 kg), w/portable base, disp kit, 35 lb (16 kg) cover, 35 lb (16 kg) follower plate, and 70 lb (32 kg) pail	244103
Falcon 50:1 Package, 35 lb (16 kg), w/disp kit, 35 lb (16 kg) cover, and 35 lb (16 kg) follower plate	244104



**Fast-Ball 1:1
Non-metered pkg.
222602**



**Fast-Ball 1:1
Metered pkg.
222702**

Fast-Ball Ordering Information

Pumps

- Fast-Ball 1:1 pump
Universal **222051**
- Fast-Ball 1:1 pump
55 gal (205 L) bung **222103**
- Fast-Ball 1:1 pump
275 gal (1100 L) bung **222104**

Packages

- Fast-Ball 1:1, non-metered disp.
package, 55 gal (205 L) **222602**
- Fast-Ball 1:1, metered disp.
package, 55 gal (205 L) **239702**

Fast-Ball Technical Specifications

- Maximum fluid pressure 180 psi (12.4 bar, 1.2 MPa)
- Air pressure range 25 to 180 psi (1.7 to 12.4 bar, 0.17 to 1.2 MPa)
- Air consumption Approximately 1.5 cfm (0.042 m³/min)
at 1 gpm (3.8 lpm) at 100 psi (0,7 MPa, 7 bar) air pressure

Sound data*

- Sound pressure level 74.9 dB(A)
- Sound power level 83.5 dB(A)
- Effective piston area 1.48 sq. in. (9.55 sq. cm)
- Maximum recommended fluid flow rate for continuous operation 2.5 gpm (9.5 lpm)
- Maximum pump operating temperature 130°F (54°C)
- Air inlet size 1/4 npt(f)
- Fluid outlet size 3/4 npt(f)

Instruction Manuals

- Fast-Ball 1:1 Pump **307906**
- Fast-Ball 1:1 Package **307637**

*Sound measurements were taken at 100 psi air (7 bar, 0.7 MPa) inlet pressure at 40 cycles per minute per ISO Standard 3744.

All written and visual data contained in this document are based on the latest product information available at the time of publication. Graco reserves the right to make changes at any time without notice.

Sales/Distribution
Toll Free, North America
800-367-4023
612-623-6743
FAX 612-623-6580
www.graco.com

Graco Inc. is registered to I.S. EN ISO 9001

